

ISTRUZIONI D'INSTALLAZIONE ED USO

ATTENZIONE: LEGGERE E CONSERVARE LE PRESENTI ISTRUZIONI

Solo il rispetto scrupoloso delle indicazioni qui contenute in sede di montaggio e di uso garantiscono la sicurezza.

L'installazione e tutte le operazioni di manutenzione non ordinarie dovranno essere effettuate solo da personale qualificato.

Disinserire l'apparecchio dalla rete di alimentazione ogni qual volta si agisce sullo stesso.

Panzeri Carlo Srl non si ritiene responsabile di eventuali danni a persone e/o cose derivati dalla errata installazione, cattivo uso o da modifiche non da essa apportate ai prodotti.

MANUTENZIONE

Si raccomanda di pulire l'apparecchio usando solo uno straccio morbido. In caso di sporco persistente inumidirlo ed eventualmente usare sapone neutro.

NON USARE alcool e/o solventi.

La sorgente luminosa contenuta in questo apparecchio deve essere sostituita solo dal costruttore, dal suo servizio di assistenza o da personale altrettanto qualificato.



L'apparecchio non può essere smaltito nei normali rifiuti domestici ai sensi della Direttiva Europea in materia di apparecchi elettrici (waste electrical and electronic equipment – WEEE). Questa direttiva definisce le norme per la raccolta e il riciclaggio degli apparecchi dismessi valide su tutto il territorio dell'unione Europea. Per la restituzione di un dispositivo dismesso, si prega di servirsi dei sistemi di restituzione e raccolta messi a disposizione nei singoli paesi di utilizzo.



Prodotto conforme alle norme di sicurezza e alle direttive europee vigenti.



Marchio unico di certificazione EAC (EurAsian Certification).

OPERATION AND USE INSTRUCTIONS

ATTENTION: PLEASE READ AND SAVE THESE INSTRUCTIONS

The safety of this fitting is only guaranteed if the instructions are followed carefully.

Installation and all non-routine maintenance must be carried out only by qualified personal.

Disconnect main voltage before taking any action on the fitting.

Panzeri Carlo Srl is not responsible for any damage to persons and/or property resulting from improper installation, misuse, or unauthorized modifications made to its products.

CLEANING

In order to clean the fitting use only a soft cloth. In case of persistent spots use only damp cloth and neutral soap.

DON'T USE alcohol and/or solvent.

The light source of this device has to be replaced by the manufacturer only, by its assistance service or by equally qualified personal.



The device may not be disposed of with household rubbish. This appliances is labelled in accordance with European Directive concerning used electrical and electronic appliances (waste electrical and electronic equipment – WEEE). The guideline determines the framework for the return and recycling of used appliances as applicable throughout the EU. To return your used device, please use the return and collection systems available to you.



Product complying with safety rules and EU directives.



Unique brand of EAC certification (EurAsian Certification).

MONTAGE- UND GEBRAUCHSANLEITUNG

ACHTUNG: BITTE LESEN UND BEWAHREN SIE DIESE ANLEITUNGEN

Um die Sicherheit der Leuchte zu gewährleisten, beachten Sie bitte unbedingt diese Anleitung.

Die Installation und alle Nicht-Routine-Wartungsarbeiten dürfen nur durch Fachpersonal durchgeführt werden.

Vor jeglichen Arbeiten ist die Stromversorgung abzustellen.

Panzeri Carlo Srl ist für eventuelle Personen- und/oder Sachschäden, die sich aus einer falschen Installation, einem unsachgemäßen Gebrauch und durch unbefugte Änderungen am Produkt ergeben, nicht verantwortlich.

REINIGUNG

Reinigung nur mit einem weichen Tuch vornehmen. Bei stärkerer Verschmutzung ein feuchtes Tuch und neutrale Seife verwenden. Auf keinen Fall Alkohol oder andere Lösungsmittel benutzen.

Die Lichtquelle enthaltene in diesem Gerät darf nur vom Hersteller, seinem Assistenzdienst oder von qualifiziertem Personal ausgetauscht werden.



Das Gerät darf nicht mit dem Hausmüll entfernt werden. Dieses Gerät ist entsprechend der europäischen Richtlinie über Elektro- und Elektronik-Altgeräte (waste electrical and electronic equipment – WEEE) gekennzeichnet. Die Richtlinie gibt den Rahmen für eine Eu-weit gültige Rücknahme und Verwertung der Altgeräte vor. Für die Rückgabe ihres Altgeräts nutzen Sie bitte die Ihnen zur Verfügung stehenden Rückgabe- und Sammelsysteme.



Das Produkt entspricht den gültigen Sicherheitsvorschriften und EU-Richtlinien.



Einegnes Markeszeugnis EAC (EurAsian Certification).

INSTRUCTIONS D'INSTALLATION ET UTILISATION

ATTENTION: S'IL VOUS PLAÎT LIRE ET CONSERVER CES INSTRUCTIONS

Seulement le respect scrupuleux des conseils ici contenus au moment de l'installation et de l'utilisation est une garantie de sécurité.

L'installation et les opérations de maintenance non-routine doivent être effectuées uniquement par du personnel qualifié.

Débrancher l'appareil du réseau d'alimentation avant de procéder à toute opération.

Panzeri Carlo Srl n'est pas responsable de tout dommage aux personnes ou choses résultant d'une mauvaise installation, mauvaise utilisation, ou de modifications aux produits apportés par les autres.

ENTRETIEN

On conseille de nettoyer l'appareil seulement avec un chiffon souple. Pour enlever les taches persistantes utiliser un chiffon humide avec du savon neutre.

Ne pas utiliser d'alcool ni de solvants.

La source lumineuse se trouvant à l'intérieur de cet appareil doit être remplacée seulement par le constructeur, par son service d'assistance ou par le personnel qualifié.



L'appareil ne peut pas être jeté dans le flux normal des déchets municipaux selon la Directive Européenne sur les déchets des équipements électriques et électroniques (waste electrical and electronic equipment – WEEE). Cette directive définit les normes de collecte et le recyclage des appareils usagés sur tout le territoire de l'Union Européenne. Pour la restitution d'un appareil usagé, il faut se servir des systèmes de restitution et de collecte offerts dans chaque pays d'utilisation.



Produit conforme aux règles de sécurité et aux règlements de l'union européenne.



Marque unique de conformité EAC (EurAsian Certification).

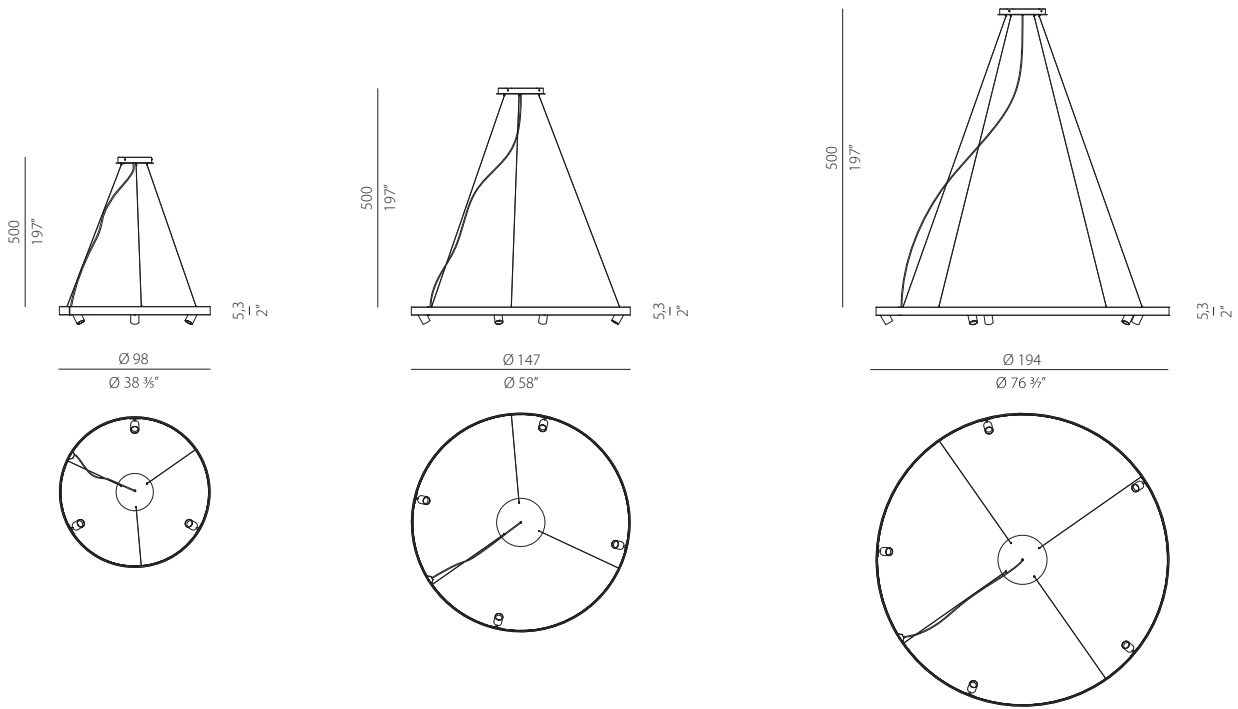

Fig. A

Fig. B

Fig. C

CODE	LAMP	WIRING VERSION	IMAGE
L074__100__18	LED	ON-OFF + DALI / PUSH DIM	A
L074__150__18	LED	ON-OFF + DALI / PUSH DIM	B
L074__200__18	LED	ON-OFF + DALI / PUSH DIM	C

L074__100__18

Dima per fori

Template for holes

Bohrschablone

Gabarit pour les trous

x = 140mm Ø = 162mm
x = 5 1/2 in Ø = 6 3/8 in

1a

L074__150__18
L074__200__18

Dima per fori

Template for holes

Bohrschablone

Gabarit pour les trous

x = 191mm Ø = 270mm
x = 7 1/2 in Ø = 10 2/3 in

1b

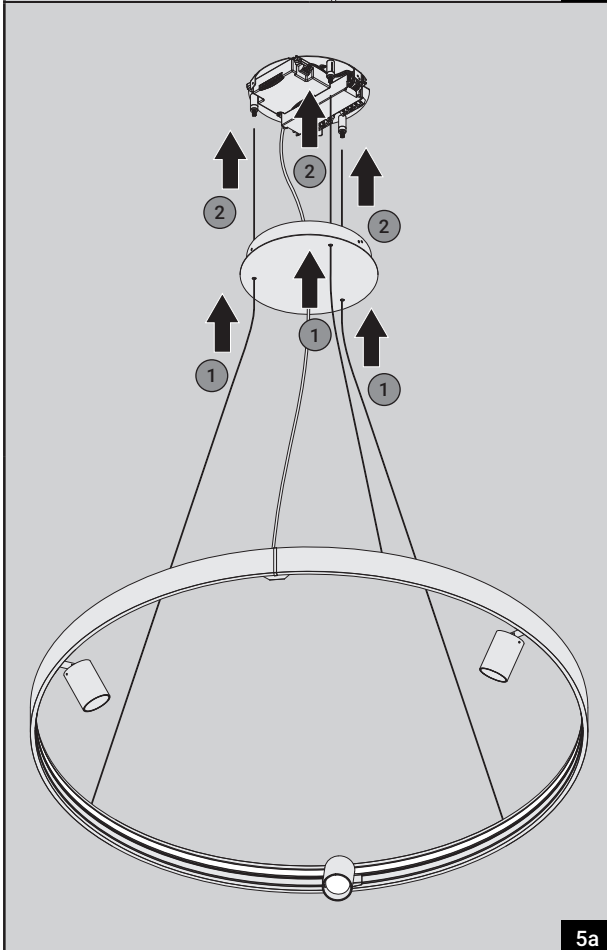
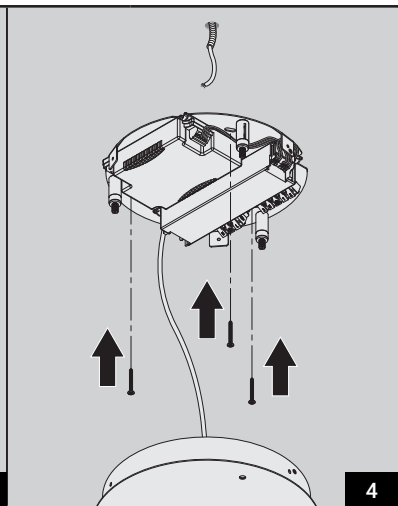
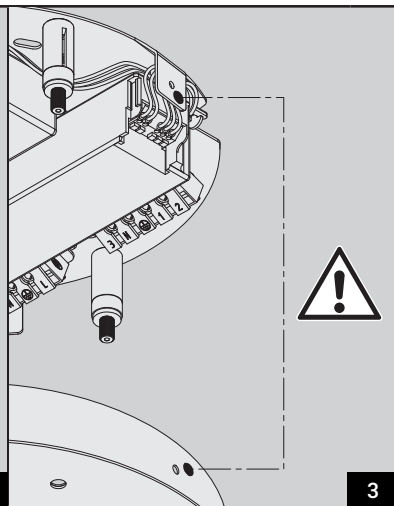
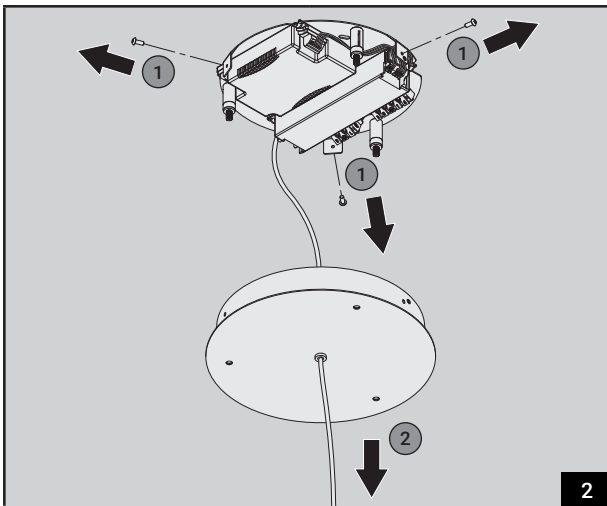

Dimma per fori

Template for holes

Bohrschablone

Gabarit pour les trous

	<p>L074_.100_.18 x = 840mm x = 33 in</p>
	<p>L074_.200_.18 x = 1360mm x = 53³/₅ in</p>

5b

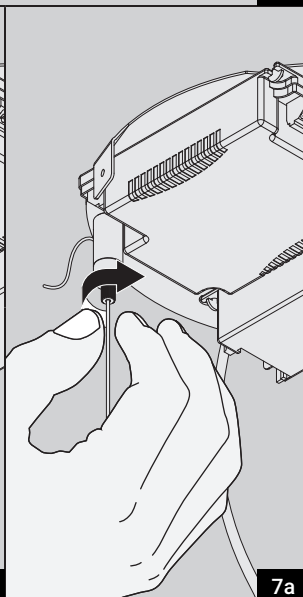
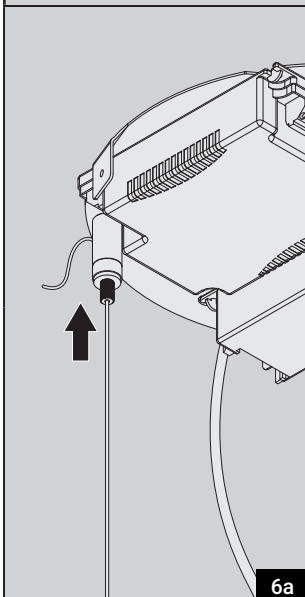
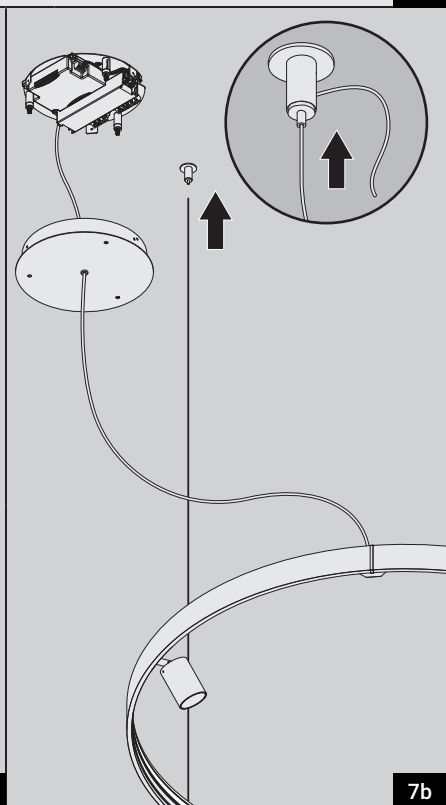
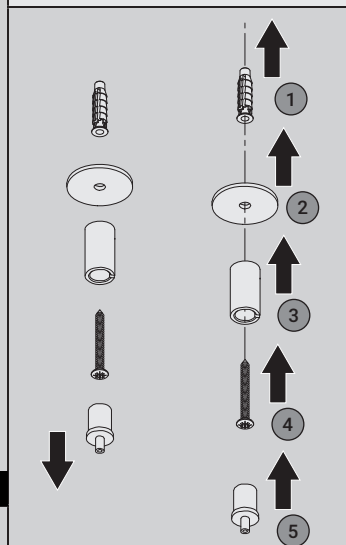

ATTENZIONE : assicurarsi che il tassello sia adeguato alla superficie di montaggio, verificando la sua tenuta.

ATTENTION : make sure that the anchor sleeve is appropriate to the supporting surface, testing its resistance.

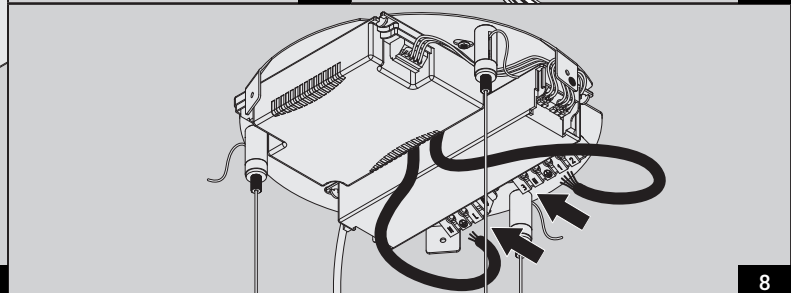

Collegamento
ON-OFF + DALI

Connection
ON-OFF + DALI

Anschluß-schei
ON-OFF + DALI

Schema de connexion
ON-OFF + DALI

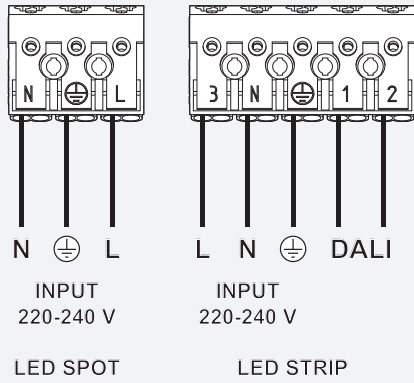

9a

Collegamento
ON-OFF + PUSH DIM

Connection
ON-OFF + PUSH DIM

Anschluß-schei
ON-OFF + PUSH DIM

Schema de connexion
ON-OFF + PUSH DIM

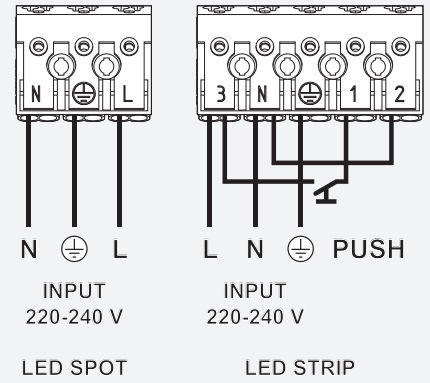

9b

Collegamento
LED STRIP

Connection
LED STRIP

Anschluß-schei
LED STRIP

Schema de connexion
LED STRIP

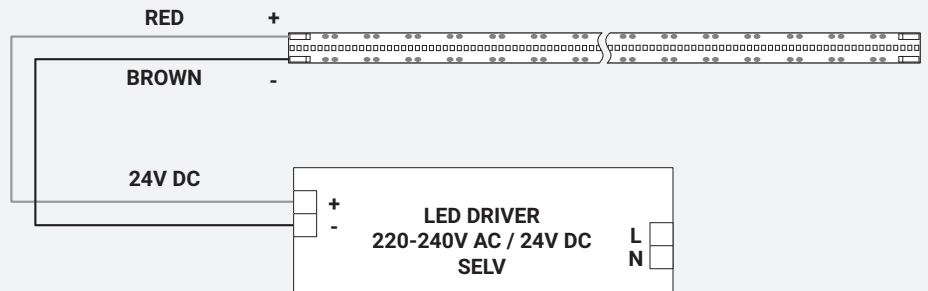

10

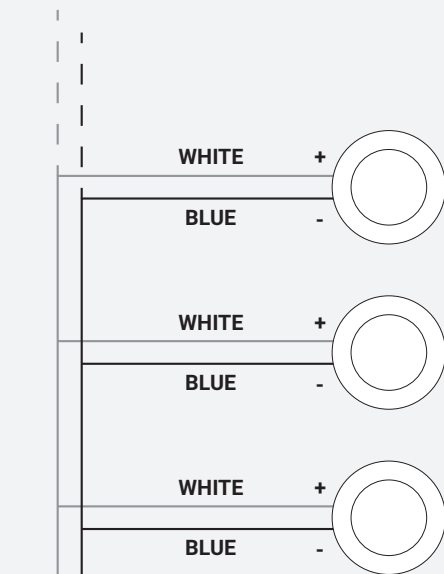

Collegamento
LED SPOT

Connection
LED SPOT

Anschluß-schei
LED SPOT

Schema de connexion
LED SPOT

11

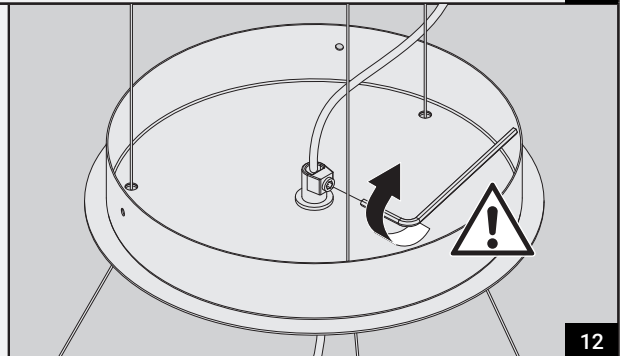

12

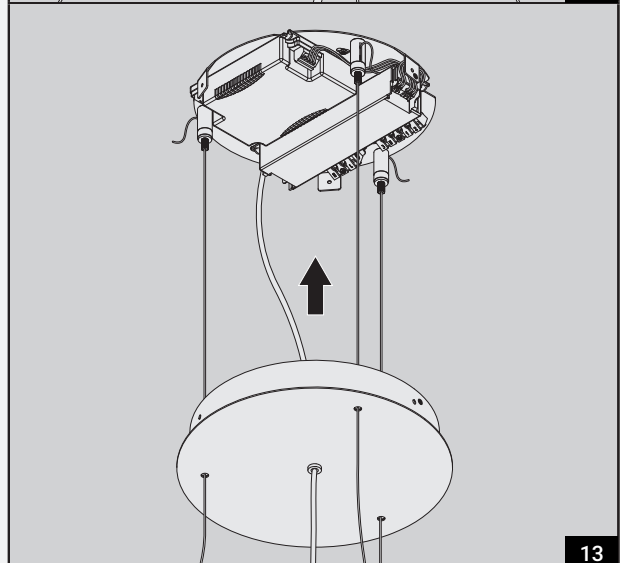

13

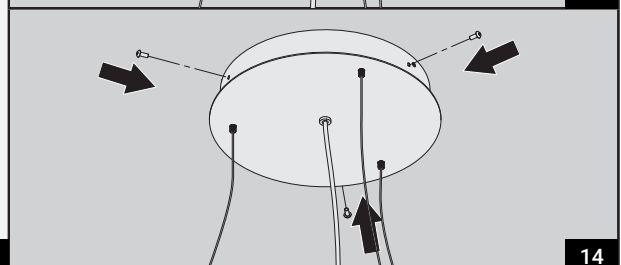

14