

Domita S/20/3L

Diseño / Design:

Benedetta Tagliabue | Joana Bover / 2019

Tipología: Suspensión

Typology: Pendant lamp

Ambiente: Interior

Environment: Indoor

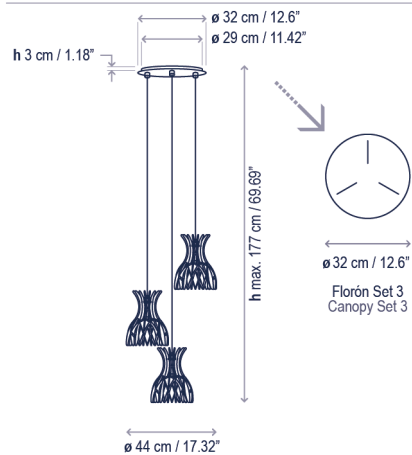
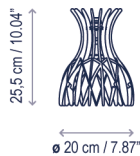

Descripción técnica / Technical description:

Peso Neto: 3,23 kg
Net Weight: 3,23 kg

1 Caja/Box | 61 x 61 x 39 cm | 0,1451 m³
Peso bruto / Gross Weight: 8,1 kg

Materiales: Hierro, Aluminio, Madera acabado haya.

Materials: Iron, Aluminum, Wood finished beech.

Florón estándar: las ranuras en el florón permiten ajustar la posición de las luminarias durante la instalación.

Standard canopy: canopy features slots for the cable connection to allow adjustability of the cluster on placement.

Cable eléctrico TPE de color negro
TPE black cable

Personalizable: consultar
Customizable: consult

Bombillas no incluidas
Bulbs not included

Regulable sólo si se utilizan bombillas regulables. /Dimmable only if dimmable bulbs are used.

Certificaciones
Certifications



Recambios / Spare parts::

RSUB258922114 Pantalla madera / Wood shade

Descripción lámpara / Lamps description:



Ref

25812200114

Acabados / Finishing

Marrón - Madera Natural
Brown - Natural Wood

Ean13

8435493724348

bover
barcelona lights

Avda. Catalunya 173
Poligon Ind. Sud
08440 Cardedeu
Barcelona, Spain

T. +34 938 713 152
F. +34 938 462 089
info@bover.es
www.bover.es

Familia / Family: Domita

