

**PINUP Polyurethane**

5027-SFBP

Design Studio Zetass

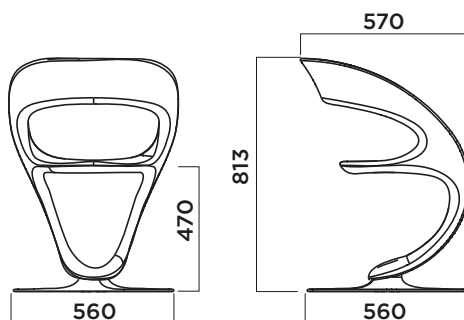

**BASE**

BASE

BASE

Stainless steel base with swivel mechanism

Base in acciaio inox con meccanismo girevole

Base de acero inoxidable con mecanismo giratorio.



**69**

**SHELL**

SCOCCA

CARCASA

Iron frame covered by complete colored soft polyurethane with avg density 250 kg/mc, fireproof class M1 and English class BS CRIB 5.

Telaio in ferro rivestito in poliuretano integrale morbido colorato con densità media 250 Kg/mc, ignifugo classe 11M e classe inglese BS CRIB 5

Bastidor de hierro recubierto de poliuretano blando de color con densidad media de 250 kg/m3, clase ignifuga M1 y clase inglesa BS CRIB 5.



**S143**



**S142**

## PINUP upholstered

5027-SFBT

Design Studio Zetass

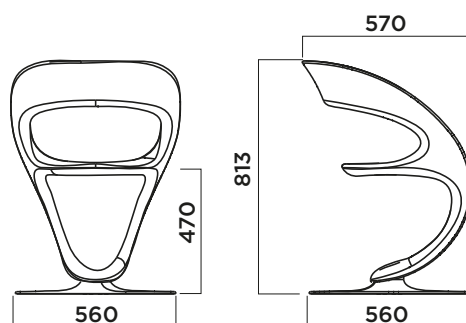

### BASE

BASE

BASE

Stainless steel base with swivel mechanism

Base in acciaio inox con meccanismo girevole

Base de acero inoxidable con mecanismo giratorio.



69

### SHELL

SCocca

CARCASA

Iron frame covered by complete colored soft polyurethane with avg density 250 kg/mc, fireproof class M1 and English class BS CRIB 5.

Telaio in ferro rivestito in poliuretano integrale morbido colorato con densità media 250 Kg/mc, ignifugo classe 11M e classe inglese BS CRIB 5

Bastidor de hierro recubierto de poliuretano blando de color con densidad media de 250 kg/m3, clase ignifuga M1 y clase inglesa BS CRIB 5.



S143



S142

### UPHOLSTERY

TAPPEZZERIA

TAPIZADOS

- A Flash, Byte
- B Eco Leather
- C N/A
- D N/A
- E Field, Oceanic , Yoredale
- F Canvas, Glow, SteelCut Trio
- G Divina3, Divina Melange, Harald, Fiord, Planum
- H Full Leather